

# Aesculap<sup>®</sup> FESS

Instruments for Functional Endoscopic Sinus Surgery



Aesculap Surgical Technologies

# Think Aesculap.



**Think Partnership.**  
Think Aesculap.



**Think Competence.**  
Think Aesculap.



**Think Service.**  
Think Aesculap.

Profound knowledge derives from appreciating the significance of individual pieces of knowledge or experience and fitting them together into a coherent network. A principle B. Braun has been following consistently for more than 170 years, clearly reflected in its corporate claim: "Sharing Expertise". Sharing knowledge across all company divisions creates a broader, sounder knowledge base for everyone involved, resulting in far-sighted, detailed solutions and maximum safety. For the benefit of the patient and in the interests of the user.

With over 140 years of experience in the surgical instrument sector, the Aesculap Division is a competent partner for this inter-disciplinary knowledge sharing process.

The Aesculap brand represents a varied spectrum that intelligently and economically combines high quality products with process-orientated services. Aesculap is a reliable and accepted partner for the entire surgical process in the hospital.

Aesculap owes its standing among the best in the business to its employees, who, searching for the best possible solution, are never satisfied with their initial idea. Who repeatedly examine, question and optimise every development.



**Think Quality.**  
Think Aesculap.

Thus, Aesculap is much more than a supplier of high precision surgical instruments: a partner who listens carefully and contributes ideas, who understands the customer's needs and requirements and provides for them on a high

level. From products to services and seminars for all areas of activity within the hospital.



**Think Economy.**  
Think Aesculap.



**Think Innovation.**  
Think Aesculap.

Profundes Wissen setzt die Vernetzung von Kenntnissen und Erfahrungen sowie deren folgerichtige Bewertung voraus. Ein Prinzip, dem B. Braun seit über 170 Jahren konsequent folgt und welches sich daher auch in der Aussage „Sharing Expertise“ ausdrücklich widerspiegelt. Ein Wissensaustausch über alle Sparten des Konzerns hinweg schafft eine breitere und somit fundiertere Wissensbasis für alle Beteiligten. Das Ergebnis sind bis ins Detail durchdachte, weitsichtige Lösungen und ein Höchstmaß an Sicherheit. Zum Wohl des Patienten und im Interesse der Anwender.

Mit über 140 Jahren Erfahrung im Segment der chirurgischen Instrumente ist die Sparte Aesculap kompetenter Partner für den interdisziplinären Wissensaustausch.

Die Produktmarke Aesculap steht für ein vielfältiges Leistungsspektrum, das hochwertige Produkte mit prozessorientierten Dienstleistungen intelligent und im Sinne der Wirtschaftlichkeit verknüpft. Aesculap ist ein verlässlicher und akzeptierter Partner für den gesamten chirurgischen Prozessablauf in der Klinik.

Dass Aesculap zu den Besten der Branche gehört, verdankt das Unternehmen seinen

Mitarbeiterinnen und Mitarbeitern, die sich auf der Suche nach der bestmöglichen Lösung nie mit der ersten Idee zufrieden geben. Menschen, die jede Entwicklung immer wieder prüfen, hinterfragen und optimieren.

Deshalb ist Aesculap weit mehr als ein Lieferant hochpräziser chirurgischer Instrumente: ein Partner, der genau zuhört und mitdenkt, die Bedürfnisse und Anforderungen seiner Kunden versteht und sie auf hohem Niveau versorgt. Vom Produkt über Dienstleistungen und Seminare für alle Funktionsbereiche.

Nasal Speculas  
Nasenspekula

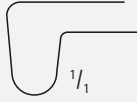

OK161R



OK162R

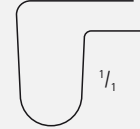

OK163R

THUDICHUM (MARK HOVELL)

OK161R	8.5 x 6.0	70 mm
OK162R	9.0 x 7.0	71 mm
OK163R	12.5 x 8.0	72 mm
OK164R	15.0 x 8.5	73 mm
OK165R	16.5 x 9.0	74 mm
OK166R	18.0 x 10.0	74 mm
OK167R	19.5 x 10.5	75 mm

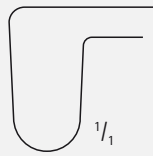

OK164R

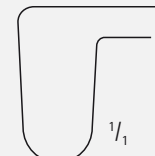

OK165R

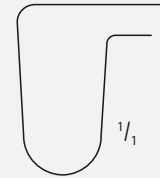

OK166R



OK167R

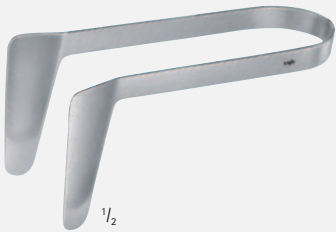

ST CLAIR THOMPSON

OK070R  
OK071R  
OK072R  
OK073R  
73 mm, 2<sup>3</sup>/<sub>4</sub>"

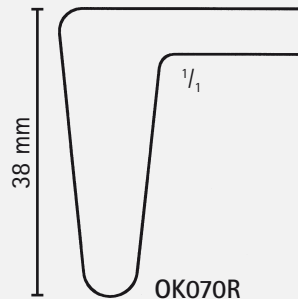

OK070R

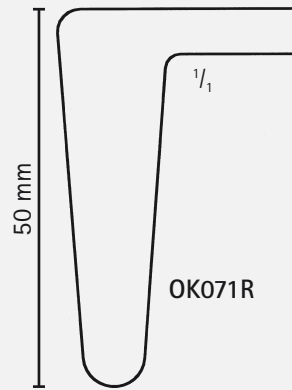

OK071R

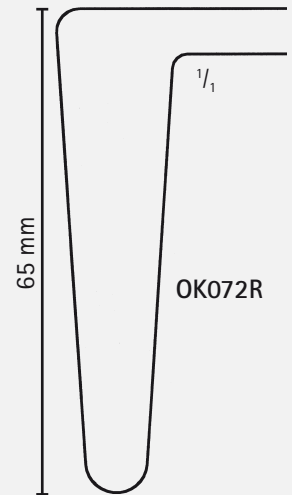

OK072R

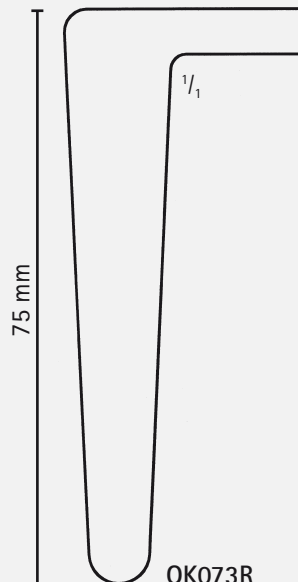

OK073R



BECKMANN

**OK053R**

with screw joint, for use in infants, curved sideways  
mit Schraubschluss, Kindermodelle, seitwärts gebogen  
140 mm, 5 1/4"

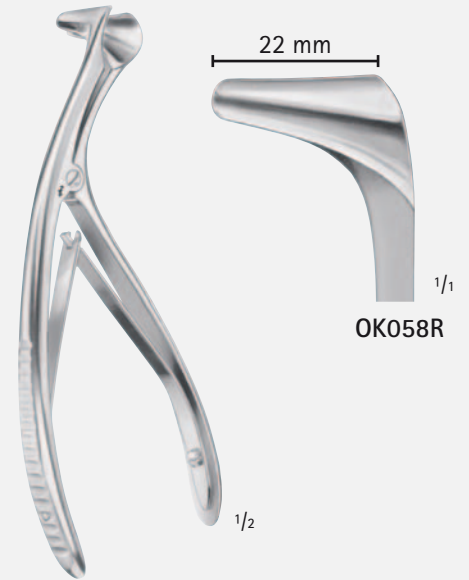

BECKMANN

**OK058R**

with screw joint, curved sideways  
mit Schraubschluss, seitwärts gebogen  
150 mm, 6"

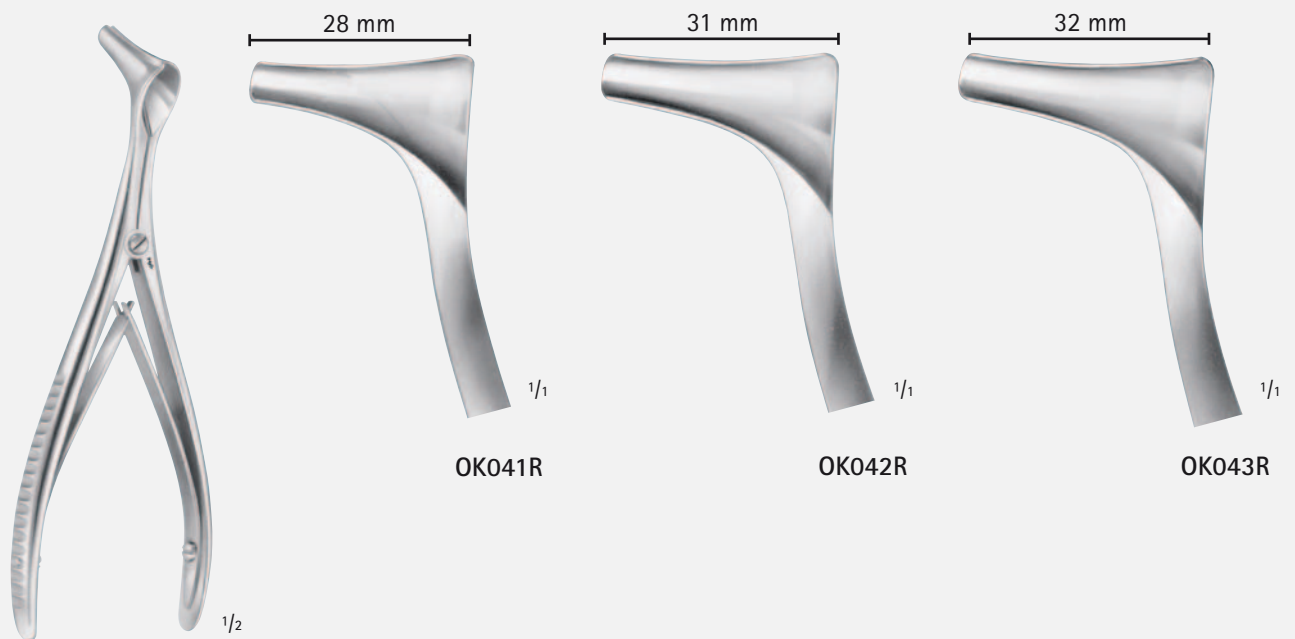

HARTMANN

**OK041R-OK043R**

with screw joint  
mit Schraubschluss  
160 mm, 6 1/4"

Nasal Speculas  
Nasenspekula

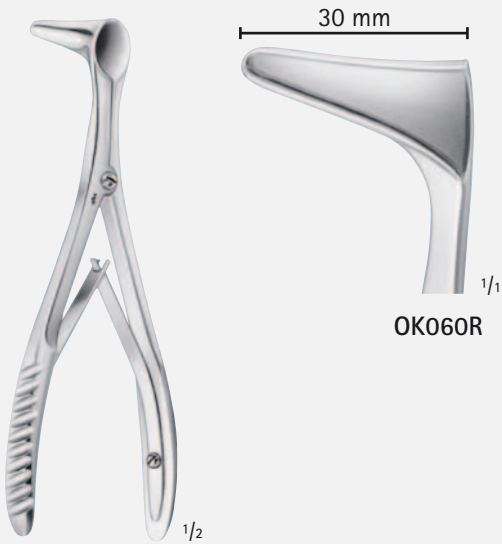

OK060R

WIENER MODELL

OK060R

with screw joint, small, light pattern

mit Schraubschluss, klein, leichte Ausführung

140 mm, 5 1/2"

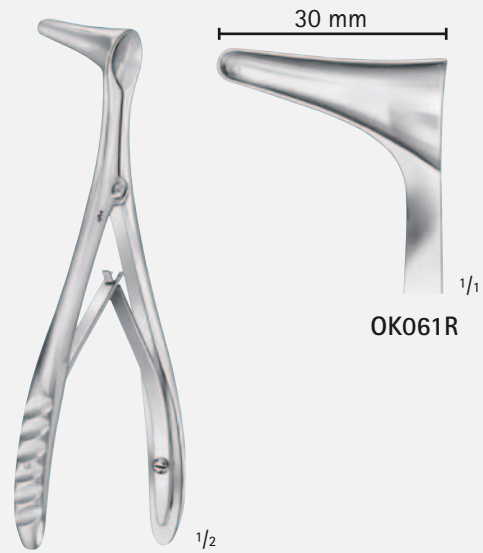

OK061R

WIENER MODELL

OK061R

with screw joint, medium, medium pattern

mit Schraubschluss, mittel, mittlere Ausführung

140 mm, 5 1/2"



OK062R

WIENER MODELL

OK062R

with screw joint, large, heavy pattern

mit Schraubschluss, groß, schwere Ausführung

140 mm, 5 1/2"



OK030R

HARTMANN

OK030R

light pattern

leichtes Modell

145 mm, 5 3/4"



KILLIAN

- OK081R Fig. 1
- OK082R Fig. 2
- OK083R Fig. 3
- OK084R Fig. 4

with aseptic joint  
mit Steckschluss  
145 mm, 5¾"

- OK091R Fig. 1
- OK092R Fig. 2
- OK093R Fig. 3
- OK094R Fig. 4

with screw joint  
mit Schraubschluss  
140 mm, 5½"

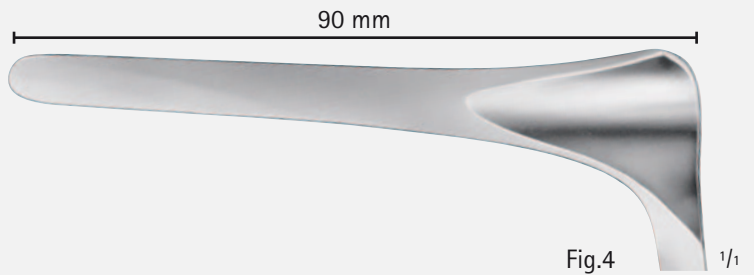
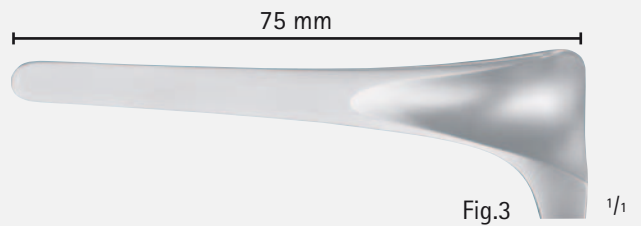
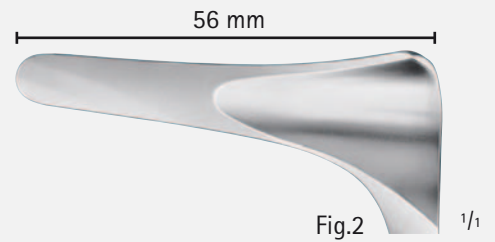
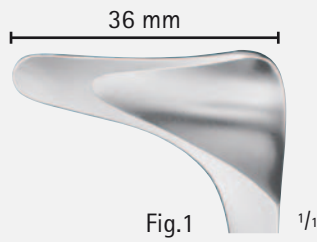

COTTLE

- OK105R-OK108R
- OK090R

with aseptic joint, set-screw, with extra thin blades  
mit Steckschluss und Stellschraube, mit besonders  
schlanken Blättern  
140 mm, 5½"

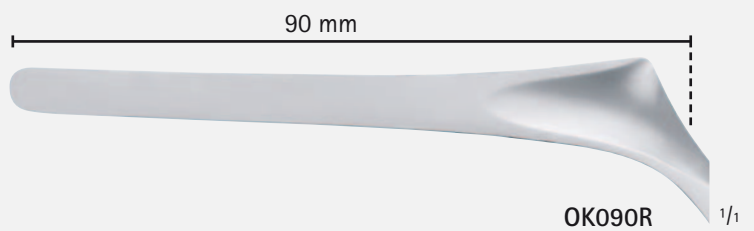
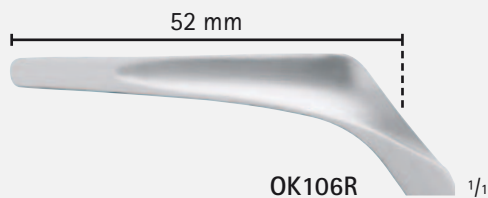
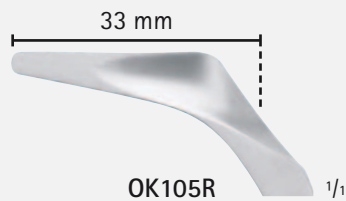



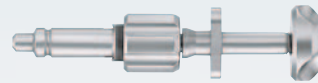

#### FH615

Handle with irrigation button for FH610R and FH611R.  
Ergonomic grasping part.

Handgriff mit Spülknopf für FH610R und FH611R.  
Ergonomischer Handgriff.

#### RT099R

Adapter for Aesculap holding arm, see page 10/11  
Adapter für Aesculap Haltearm, siehe Seite 10/11



#### FH605SU

Suction and irrigation tube, sterile, 4.5m, with 2  
puncture needles, for handle FH615  
and FH610R/FH611R

Sales unit:  
PAK= Package of 10 tubes

Spül-/Saugschlauch, steril, 4.5m, mit 2 Punktionskanülen  
für Griff FH615 und FH610R/FH611R

Bestelleinheit:  
PAK= Packung à 10 Schlauchsets

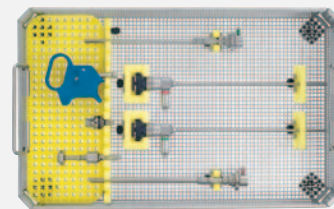

#### FF357R

Storage tray with silicone padding and lid for all MINOP®  
TREND components (without instruments)

Lagerungstray mit Silikon-Lagerungsstegen und Deckel für  
alle MINOP® TREND Komponenten (ohne Inhalt)



### FH610R

Suction and irrigation trocar for  
0° endoscope PE487A,  
Diam. 4.5 / 6.0 mm

Spül-/Saugtrokar für 0°-Endoskop  
PE487A, Ø 4.5 / 6.0 mm

120 mm, 4¾"

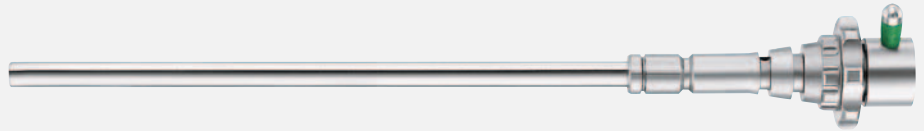

### FH611R

Suction and irrigation trocar for  
30° endoscope PE507A,  
Diam. 4.5 / 6.0 mm

Spül-/Saugtrokar für 30°-Endoskop  
PE507A, Ø 4.5 / 6.0 mm

120 mm, 4¾"

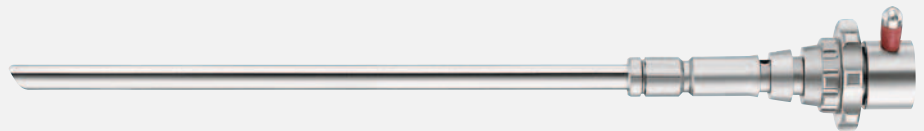

### PE487A

Endoscope, 0° viewing angle

Endoskop, Blickrichtung: 0°

Diam. 4.0 mm / Ø 4.0 mm

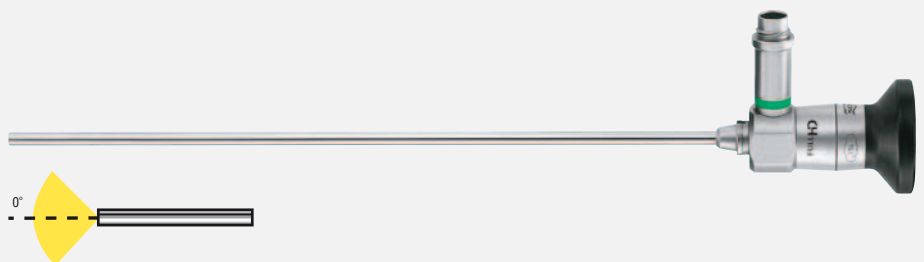

### PE507A

Endoscope, 30° viewing angle

Endoskop, Blickrichtung: 30°

Diam. 4.0 mm / Ø 4.0 mm

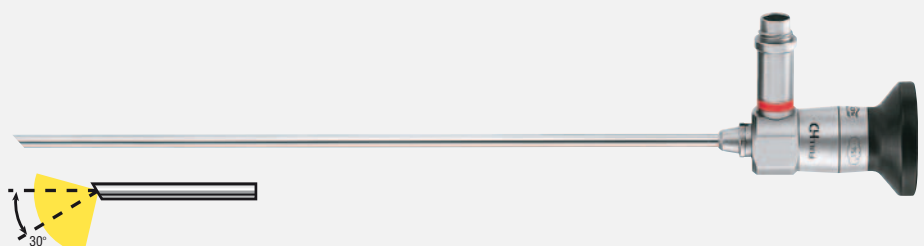



**RT040R**  
**Unitrac® - Pneumatic Holding Arm**

- Single handed use
- Fast sterile set-up in the OR
- Simple to assemble onto the OR table railing
- Integrated safety systems prevent collapse of holding arm if OR compressed air supply is interrupted
- Direct connection to OR compressed air supply or to CO<sub>2</sub> cartridge
- Holding Force: 4 kg

**RT040R**  
**Unitrac® - Pneumatischer Haltearm**

- Einmal-Bedienung
- Schnelle sterile Bereitstellung im OP
- Einfache Montage an OP-Schiene
- Integrierte Sicherheitssysteme verhindern ein Kollabieren des Haltearms bei möglichem Ausfall der OP-Druckluftversorgung
- Direkter Anschluss an die vorhandene OP-Druckluftversorgung oder die CO<sub>2</sub> Druckluft-Kartusche
- Haltekraft: 4 kg



**Unitrac® Air Cartridge: the hose-less "Plug and Play" solution for Unitrac®**

- No need for laying hoses
- Avoid tripping hazard in the OR
- Always constant working pressure
- Overload valve secured
- Fast and easy change of cartridges

**Die Schlauchlose "Plug and Play" Lösung für Unitrac®**

- Einsatz des Unitrac® unabhängig von einem Druckluftanschluss
- Vermeidet dadurch Stolperfallen im Operationssaal
- Gewährt konstanten Betriebsdruck
- Sicher durch Überdruckventil
- Schneller und einfacher Kartuschenwechsel

**RT043R**  
CO<sub>2</sub> Air Cartridge adapter  
For use of Unitrac® independent from compressed air sources

**RT043R**  
CO<sub>2</sub> Kartuschenadapter für den Einsatz des Unitrac® unabhängig von einem Druckluftanschluss

**RT044SU**  
Unitrac® CO<sub>2</sub> Air Cartridge  
pack of 10 pcs, Single use product

**RT044SU**  
Unitrac® CO<sub>2</sub> Druckluftkartusche  
Pack mit 10 Stück, Single Use



**RT090R**  
Flexible fixing element with sprocket suitable for RT040R and FF168R

**RT090R**  
Flexible Verbindungsklemme zur OP-Schiene. Passend für RT040R und FF168R



#### JG901

Sterile drape for coverage of the Unitrac® arms, single use product, package of 50 pcs

Steriler Überzug für den Unitrac® Haltearm, Single-use, Pack à 50 Stk.

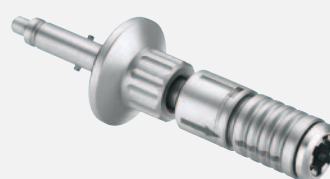

#### RT020R

Quick connect adapter for use with sterile drape JG901 allows the change of instruments after draping with JG901

Schnellverschluss Adapter für die Verwendung mit dem Sterilüberzug JG901. Ermöglicht den Instrumentenwechsel nach dem Abdecken mit JG901.



Unitrac® in combination with MINOP® TREND

Unitrac® in Verbindung mit MINOP® TREND

Nasal Scissors  
Nasenscheren

**OK560R**

straight, blades serrated  
gerade, Schneiden gezahnt

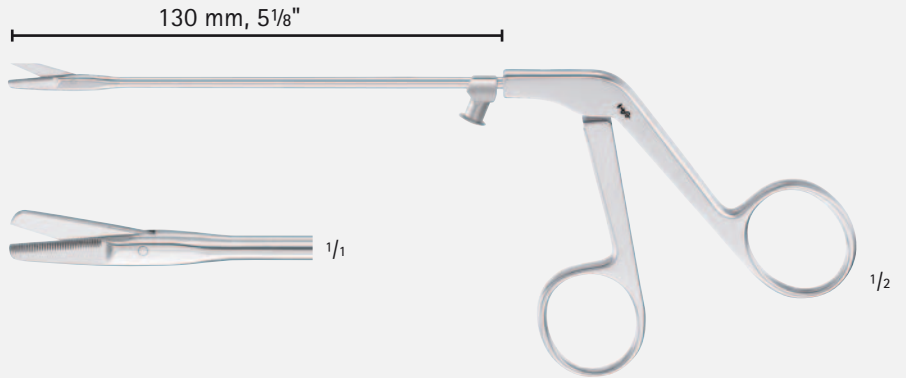

**OK560R - OK562R**

Nasal scissors  
Nasenscheren

**OK561R**

left curved, blades serrated  
links gebogen, Schneiden gezahnt

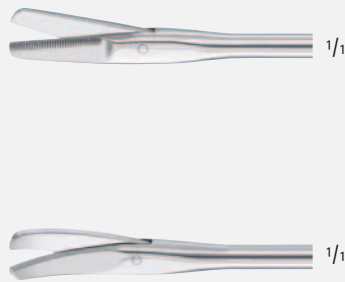

**OK562R**

right curved, blades serrated  
rechts gebogen, Schneiden gezahnt

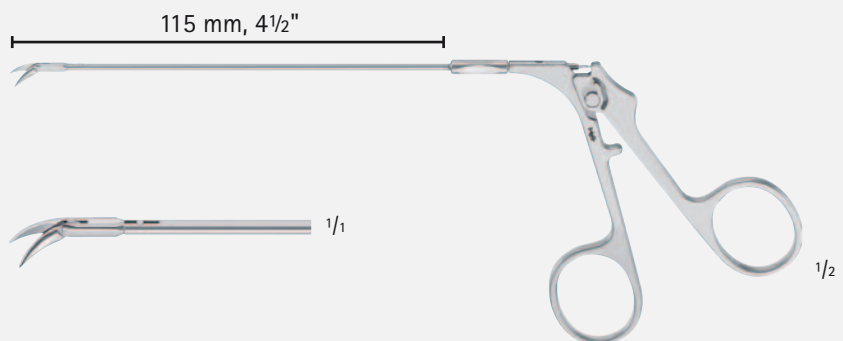

**CASPAR**

**FD228R**

Micro scissors, curved  
rotatable 360°  
Mikroschere, gebogen,  
360° drehbar



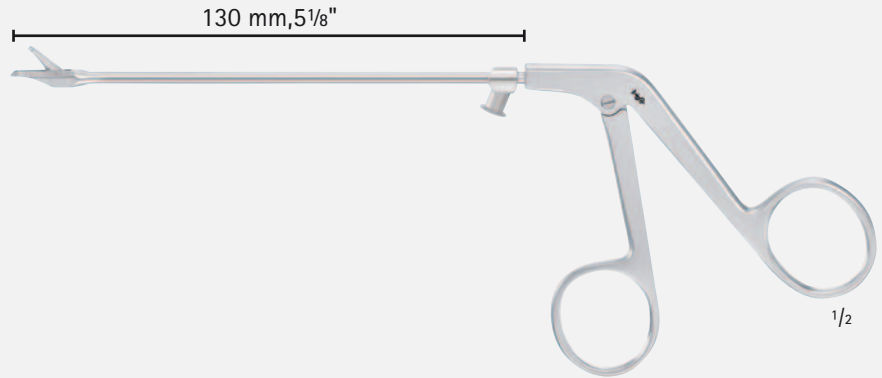

Sinus Punches, Antrum Punch  
Nasennebenhöhlen-Stanzen, Antrumstanze



OK602R-OK609R

Sinus Punches

Nasennebenhöhlen-Stanzen

		 2/1 6 x 1.5 mm	 2/1 8 x 3 mm	 2/1 11.5 x 3.5 mm
	straight gerade	<b>OK608R</b> forward through cutting nach vorne durchschneidend	MACKAY-GRUNEWALD <b>OK602R</b> forward through cutting nach vorne durchschneidend	MACKAY-GRUNEWALD <b>OK603R</b> forward through cutting nach vorne durchschneidend
	45° upwards angled 45° nach oben gebogen	<b>OK609R</b> forward through cutting nach vorne durchschneidend	MACKAY-GRUNEWALD <b>OK606R</b> forward through cutting nach vorne durchschneidend	MACKAY-GRUNEWALD <b>OK607R</b> forward through cutting nach vorne durchschneidend

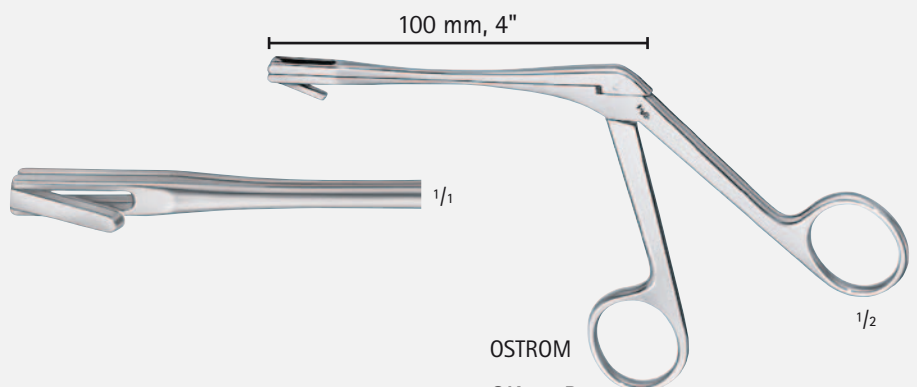

OSTROM

OK704R

Antrum punch reverse action jaw

Antrumstanze, rückwärts schneidend

Antrum Punches  
Antrumstanzen

**OK580R**

backbiting straight  
rückwärts gerade schneidend

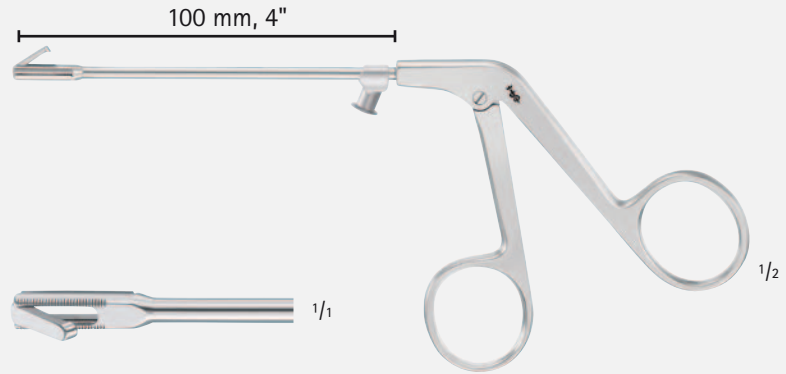

STAMMBERGER

**OK580R - OK582R**

Antrum Punches  
Antrumstanzen

**OK581R**

backbiting to the right  
rückwärts nach rechts schneidend



**OK582R**

backbiting to the left  
rückwärts nach links schneidend



**OK583R**

forward cutting downwards to the right  
nach rechts unten vorwärts schneidend

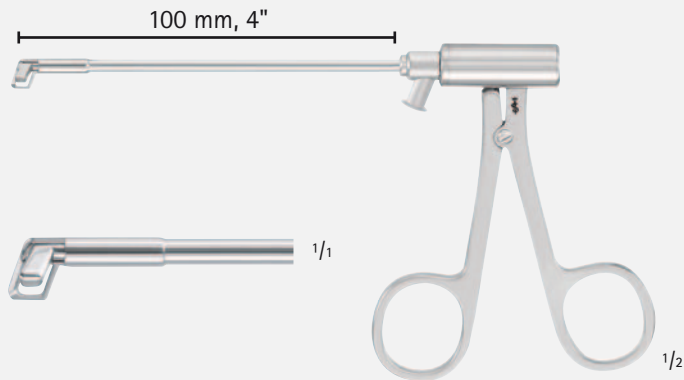

STAMMBERGER

**OK583R - OK584R**

Antrum Punches  
Antrumstanzen

**OK584R**

forward cutting downwards to the left  
nach links unten vorwärts schneidend





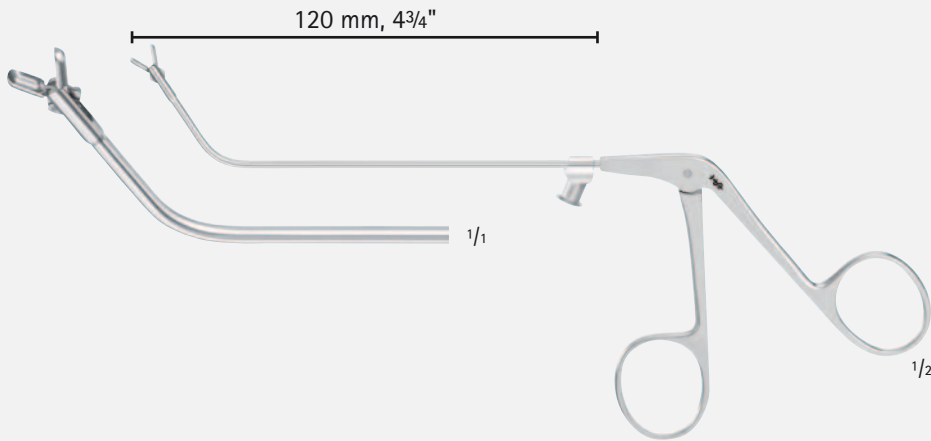

**OK620R**

Giraffe Forceps, upwards curved, cup size diam. 3 mm, double action

Giraffenzange, aufwärts gebogen, Löffelgröße Ø 3 mm, doppelbeweglich

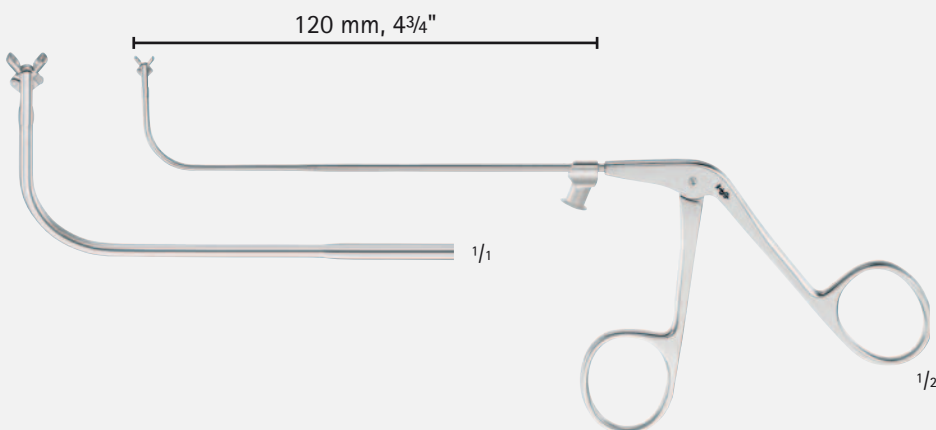

**OK621R**

Giraffe Forceps, strongly upwards curved, cup size diam. 2 mm, double action

Giraffenzange, stark aufwärts gebogen, Löffelgröße Ø 2 mm, doppelbeweglich

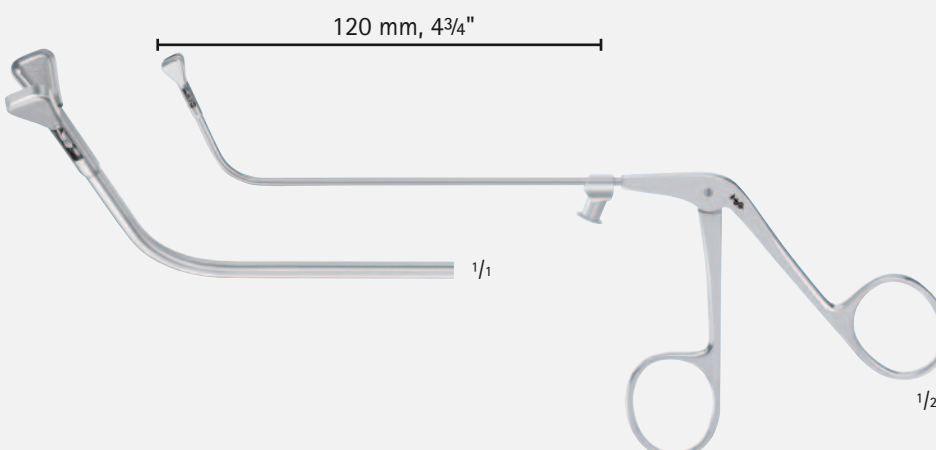

**OK622R**

Giraffe Forceps, upwards curved, jaw size 4 x 6 mm, double action

Giraffenzange, aufwärts gebogen, Maulgröße 4 x 6 mm, doppelbeweglich

Antrum Grasping Forceps  
Antrum-Fasszangen

**OK680R**

jaw opening backwards, curved downwards  
rückwärts öffnend, nach unten gebogen

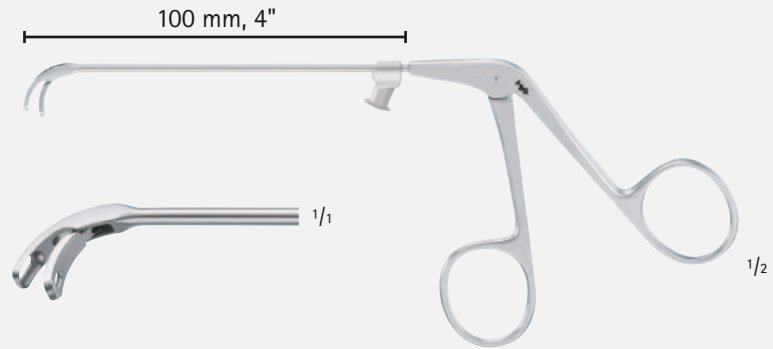

OK680R - OK683R

**OK681R**

jaw opening backwards, curved upwards  
rückwärts öffnend, nach oben gebogen



**OK682R**

jaw opening backwards, curved to right  
rückwärts öffnend, nach rechts gebogen



**OK683R**

jaw opening backwards, curved to left  
rückwärts öffnend, nach links gebogen

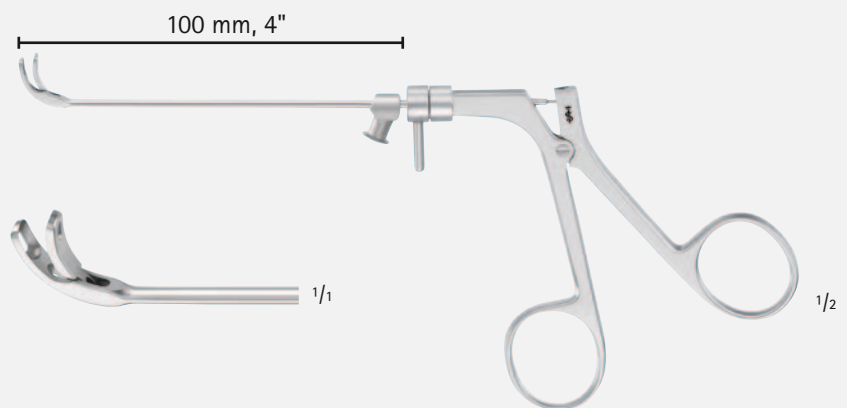

**OK684R**

jaw opening backwards,  
jaw 360° rotatable  
rückwärts öffnend,  
Maul 360° drehbar

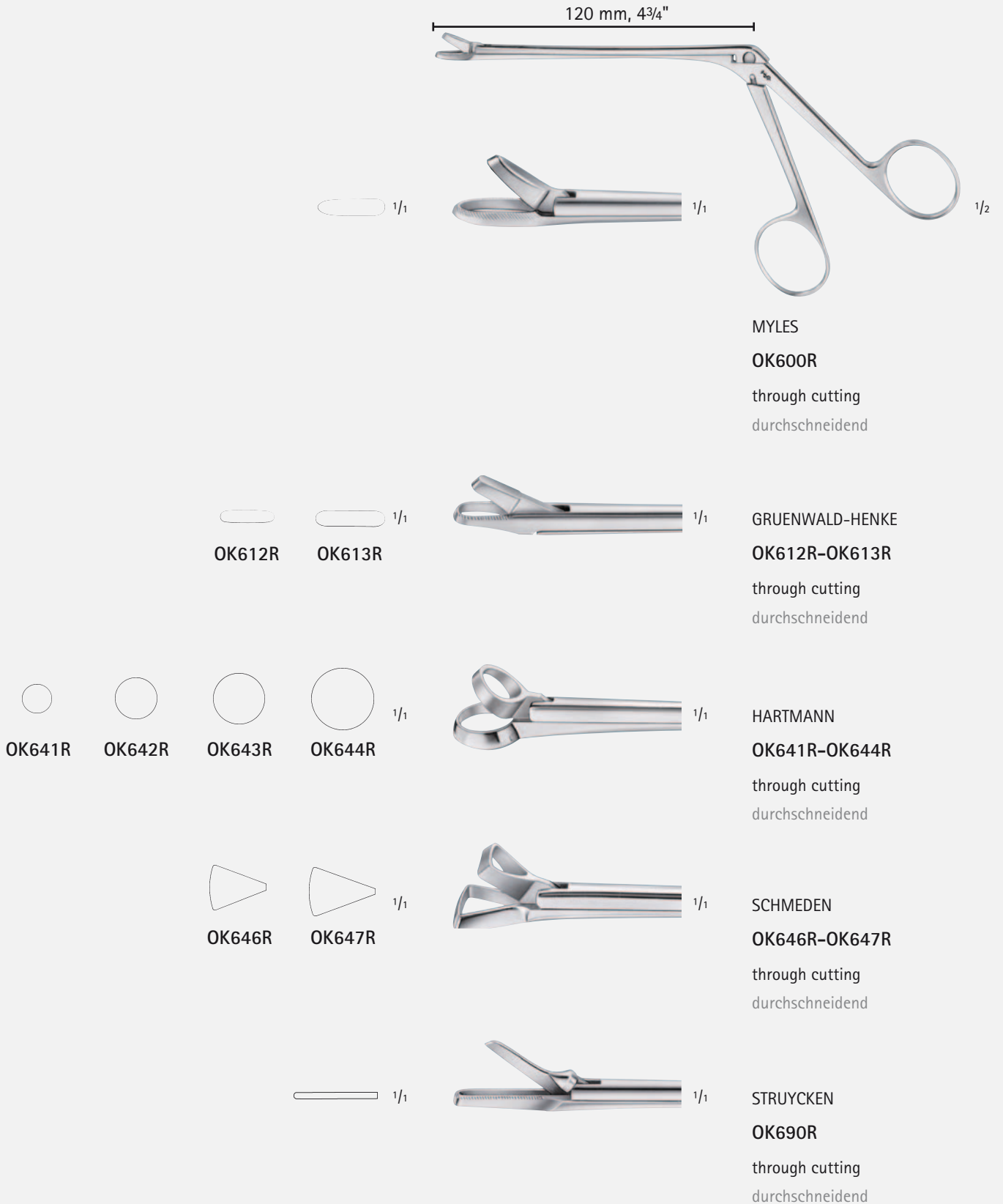

## Nasal Forceps Nasenzangen

Angled positions for rongeurs  
Winkelstellungen bei Rongeuren

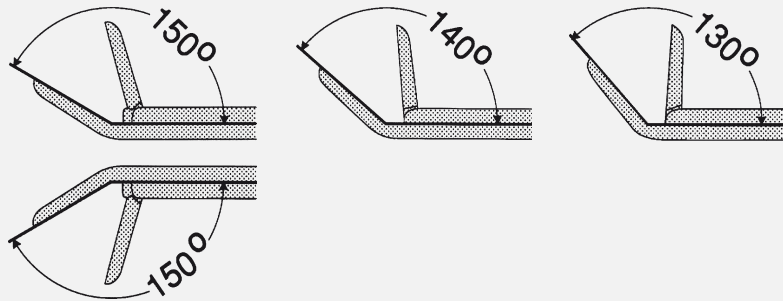

OK505R  
3.0 mm



OK506R  
3.6 mm



OK507R  
4.2 mm



OK508R  
4.8 mm



OK509R  
5.6 mm

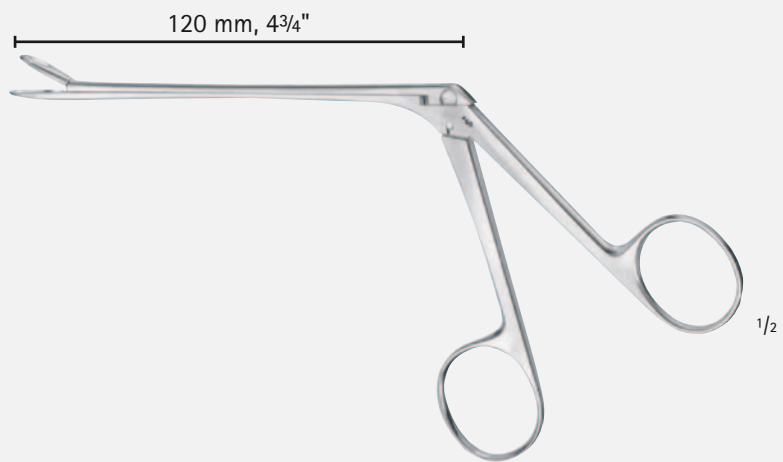

BLAKESLEY-WILDE  
OK505R-OK509R

Ethmoidal forceps, straight  
Siebbeinzange, gerade

OK520R  
3.6 mm



OK521R  
4.2 mm



OK522R  
4.8 mm

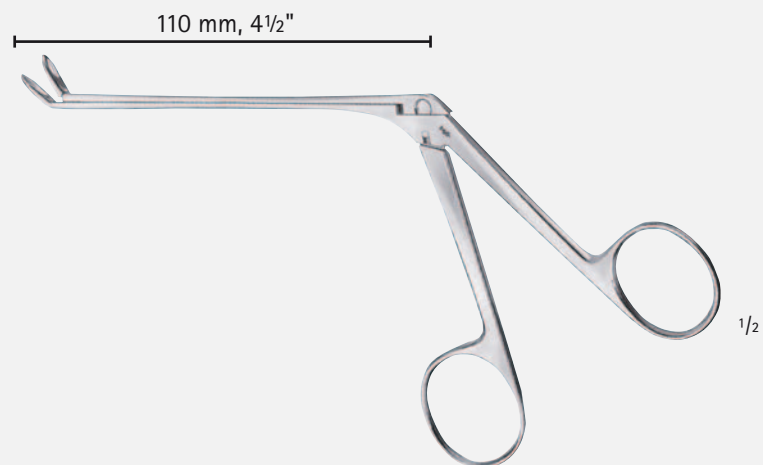

BLAKESLEY-WILDE

OK520R-OK522R 140°

Ethmoidal forceps, upwards curved  
Siebbeinzange, aufwärts gebogen

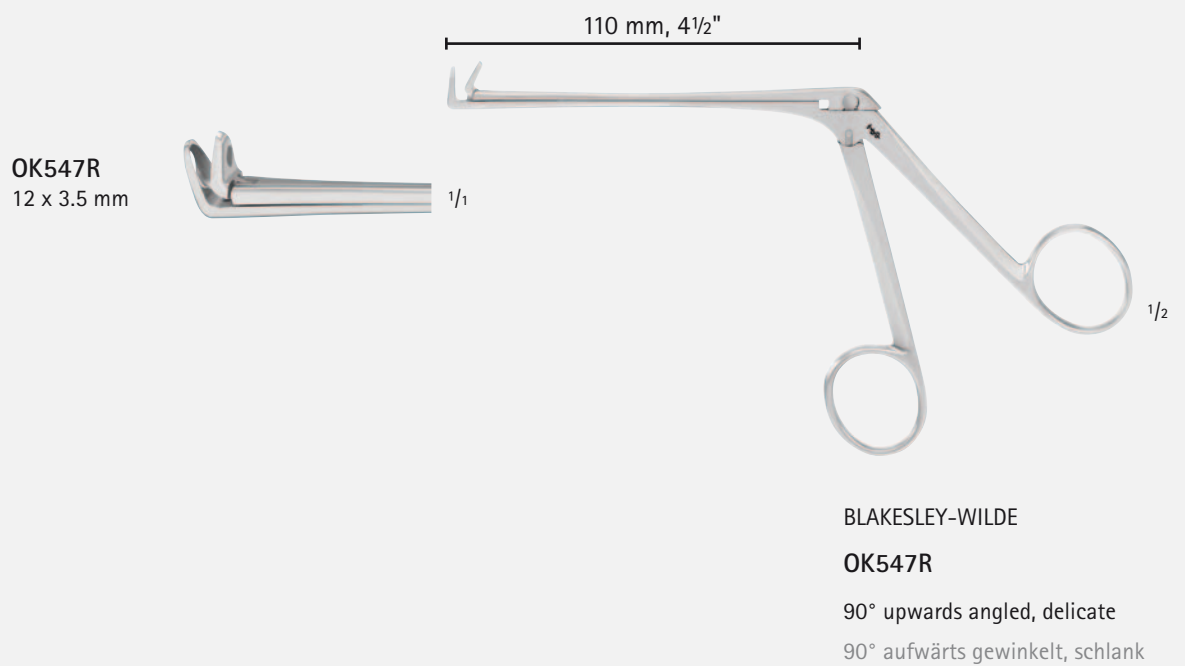
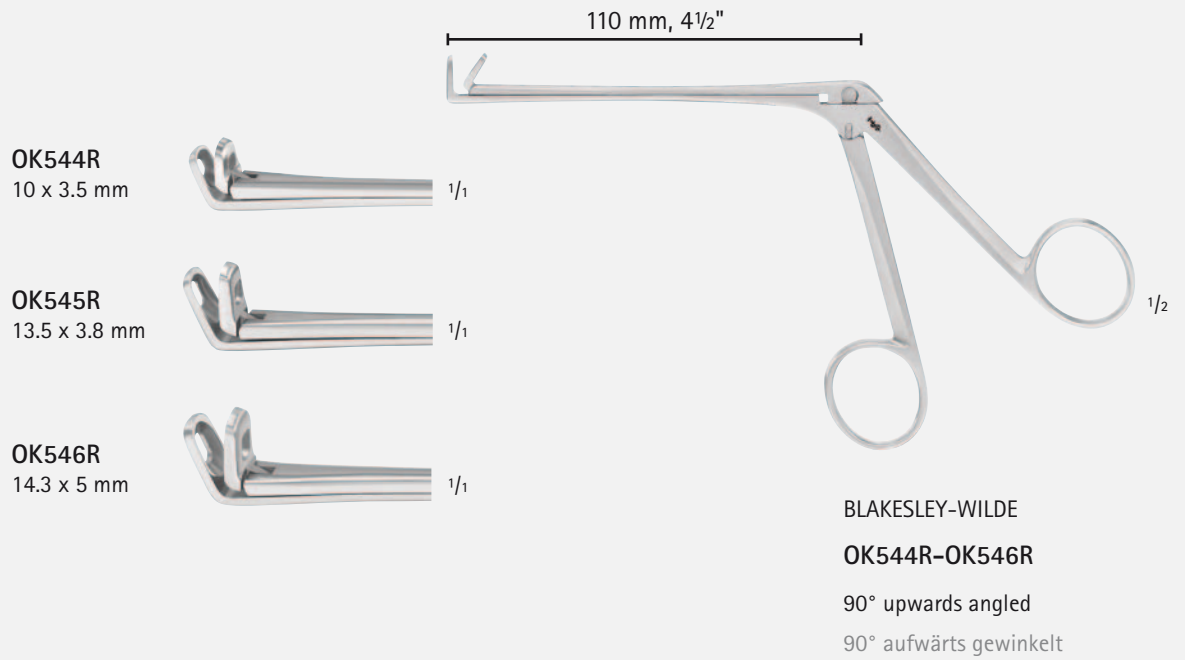

Nasal Forceps, Rongeurs  
Nasenzangen, Rongeure

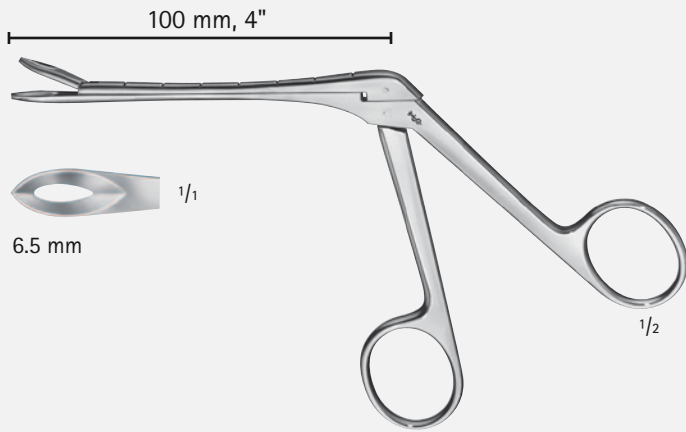

HENCKEL-TILLEY

**OK503R**

Ethmoidal forceps, Shaft graduated in cm  
Siebbeinzange, Schaft graduert in cm

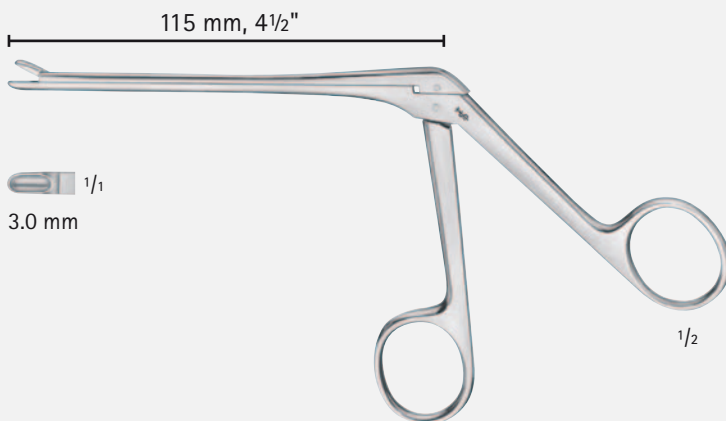

ST. BARTS

**OK536R**

Rongeur, straight  
Rongeur, gerade

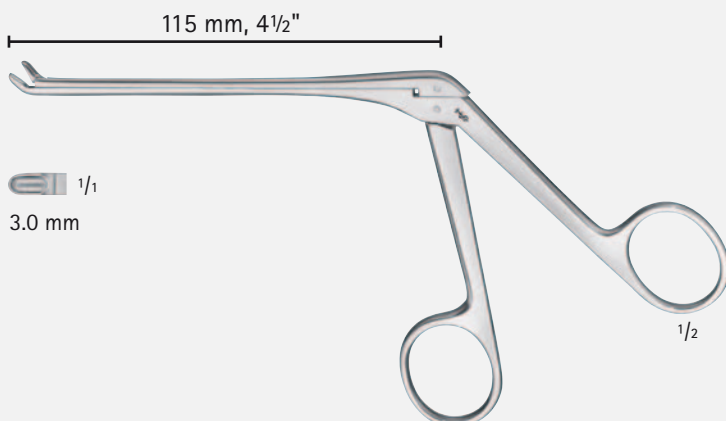

ST. BARTS

**OK537R 140°**

Rongeur, upwards cutting  
Rongeur, nach oben schneidend



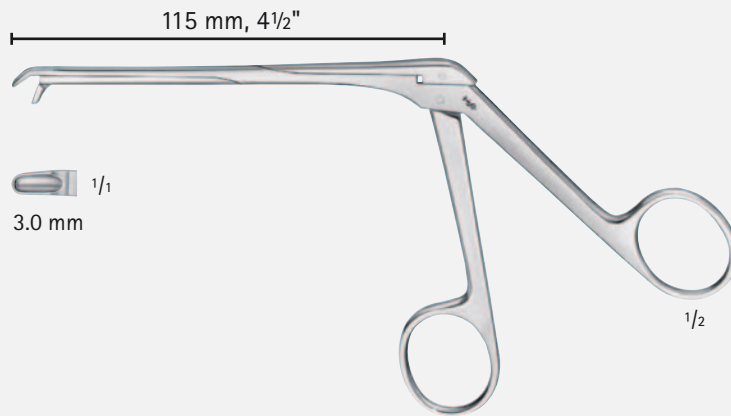

ST. BARTS  
**OK538R** 140°  
Rongeur, downwards cutting  
Rongeur, nach unten schneidend

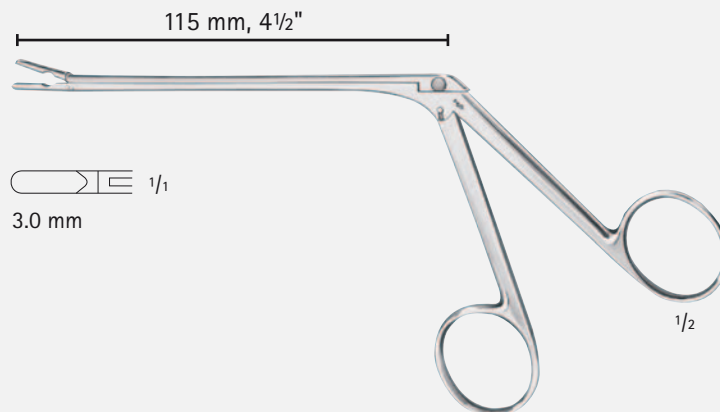

TAKAHASHI  
**OK525R**  
Rongeur, straight  
Rongeur, gerade

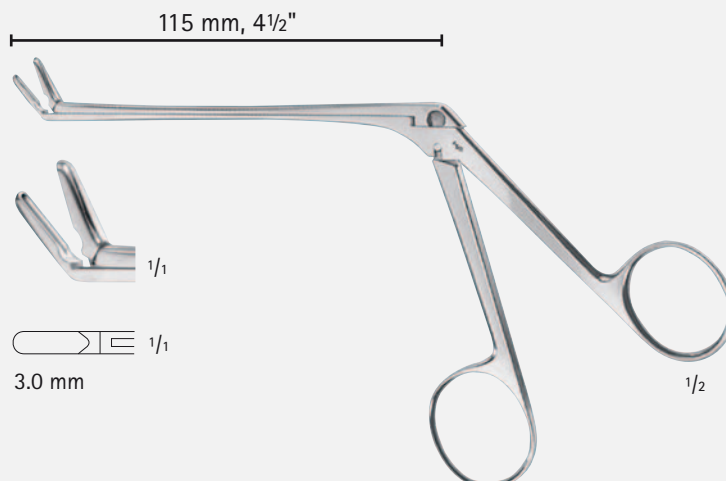

TAKAHASHI  
**OK526R** 130°  
Ethmoidal forceps, upwards curved  
Siebbeinzange, aufwärts gebogen

Nasal Forceps, Rongeurs  
Nasenzangen, Rongeure

OK527R  
5 mm

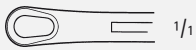

1/1



1/1

OK529R  
7 mm

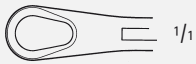

1/1



1/1

OK531R  
9 mm

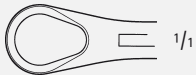

1/1



1/1

120 mm, 4<sup>3</sup>/<sub>4</sub>"

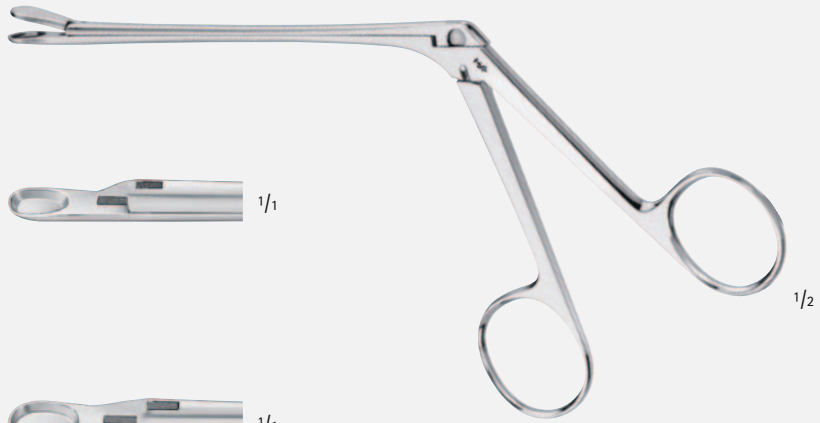

1/2

WATSON-WILLIAMS  
OK527R-OK531R

120 mm, 4<sup>3</sup>/<sub>4</sub>"

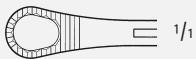

1/1



1/1



1/2

WATSON-WILLIAMS  
OK530R

Ethmoidal forceps for mucosa,  
serrated jaws

Fasszange für Schleimhaut,  
gezahnt



**OF601R**

Sickle knife, sharp tip  
Sichelmesser, spitz  
190 mm, 7 1/2"



**FK650R**

Antrum curette, oval  
Antrumlöffel, oval  
190 mm, 7 1/2"



**FK651R**

9.5 x 4 mm

**FK651R-FK652R**

Antrum curette, oval  
Antrumlöffel, oval  
190 mm, 7 1/2"

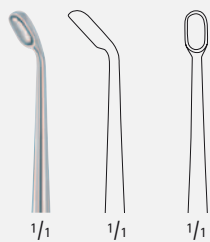

**FK652R**

6 x 3 mm



**FK653R**

6 x 3 mm

slightly curved  
leicht gebogen

**FK653R-FK654R**

Frontal sinus curette, oval  
Stirnhöhlenlöffel, oval  
190 mm, 7 1/2"

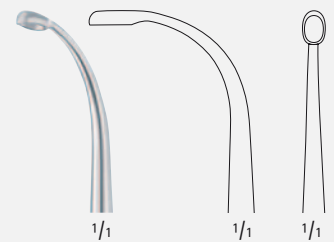

**FK654R**

6 x 3 mm

strong curved  
stark gebogen

Curettes, Antrum Retractor, Antrum Trocar  
 Küretten, Antrumahaken, Antrumtrokar



COAKLEY  
**OK811R-OK816R**  
 Antrum curettes  
 Antrumküretten  
 170 mm, 6<sup>3</sup>/<sub>4</sub>"



BRÜNINGS-BRUNK  
**OK800R**  
 Antrum retractor  
 Antrumahaken  
 190 mm, 7<sup>1</sup>/<sub>2</sub>"

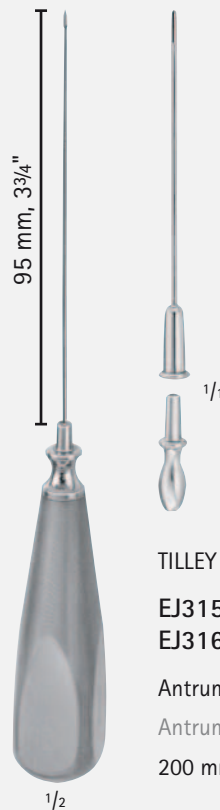

TILLEY LICHTWITZ  
**EJ315R** Diam. / Ø 1.7 mm  
**EJ316R** Diam. / Ø 2.0 mm  
 Antrum trocar  
 Antrumtrokar  
 200 mm, 8"

Irrigating Cannulas, Antrum Trocars, Antrum Rasps  
Spülröhrchen, Antrumtrokare, Antrumtrephine



EIKEN

**OK874C** Diam. / Ø 2.5 mm

**OK875C** Diam. / Ø 3.0 mm

Irrigating cannula, LUER cone, strong curved

Spülröhrchen, LUER Konus, stark gebogen

130 mm, 5 1/8"



EIKEN

**OK876R** Diam. / Ø 2.5 mm

Irrigating cannula, LUER cone, slightly curved

Spülröhrchen, LUER Konus, schwach gebogen

145 mm, 5 3/4"



EIKEN

**OK877R** Diam. / Ø 2.5 mm

Irrigating cannula, LUER cone, shortly curved

Spülröhrchen, LUER Konus, kurz gebogen

145 mm, 5 3/4"

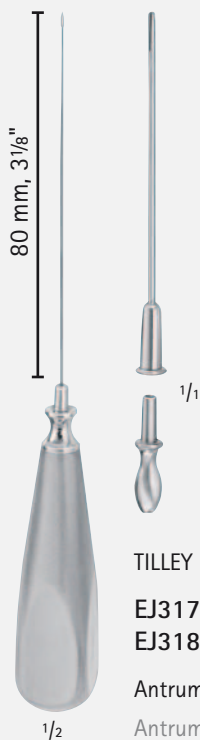

TILLEY LICHTWITZ

**EJ317R** Diam. / Ø 2.3 mm

**EJ318R** Diam. / Ø 2.7 mm

Antrum trocar

Antrumtrokar

185 mm, 7 1/4"



**OK805R**

blunt  
stumpf

**OK804R**

sharp  
spitz

**OK804R-OK805R**

Antrum rasp, American pattern

Antrumtrephine, amerikanisches Modell

190 mm, 7 1/2"

Frontal Sinus Ostium Seeker, Trocars, Irrigating Cannula, Frontal Sinus Bougies  
 Stirnhöhlen-Doppelinstrument, Trokare, Spülkanüle, Stirnhöhlerdilator

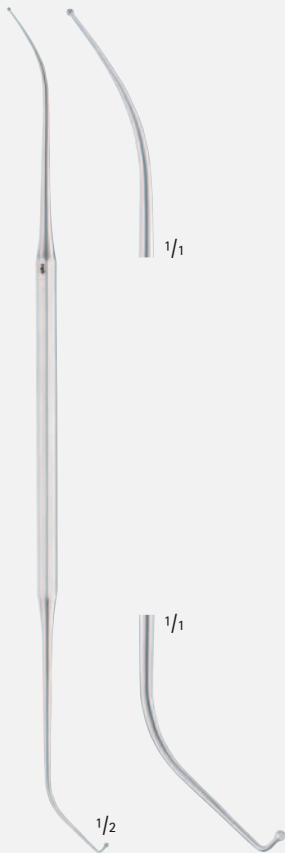

**BN175R**

Frontal sinus ostium seeker,  
 double ended, curved

Stirnhöhlen-Doppelinstrument,  
 gebogen

220 mm, 8 5/8"



**EJ305R**

Sinuscopy trocar, for use with 4  
 mm Endoscopes

Sinuskopie Trokar, für 4 mm  
 Endoskope

Inner diam. / Innen-Ø 5.0 mm

180 mm, 7"

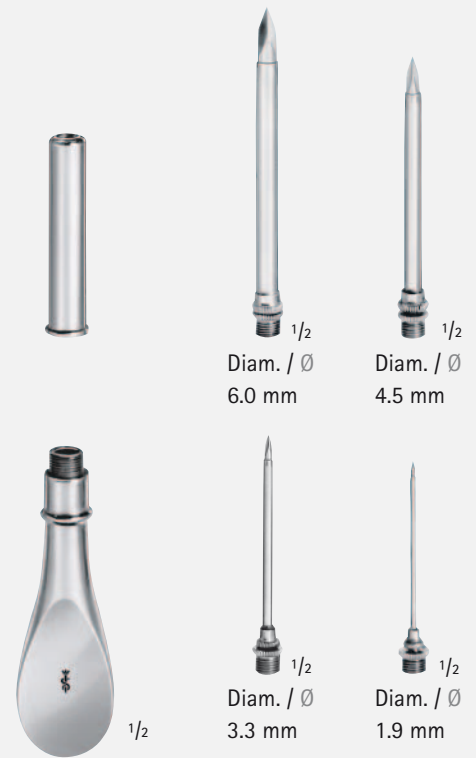

**EJ126R**

Universal trocar with 4 tips

Universaltrokar mit 4 Aufsätzen



**HAJEK**

**OK900**

Irrigating cannula, silver

Spülkanüle aus Silber

Diam. of tip / Knopf-Ø 3.5 mm

165 mm, 6 1/2"

1/2



**RITTER**

**OK921R** Diam. / Ø 2.5 mm

**OK922R** Diam. / Ø 3.0 mm

**OK924R** Diam. / Ø 4.0 mm

**OK926R** Diam. / Ø 5.0 mm

Frontal sinus bougie

Stirnhöhlerdilator

150 mm, 6"

1/2





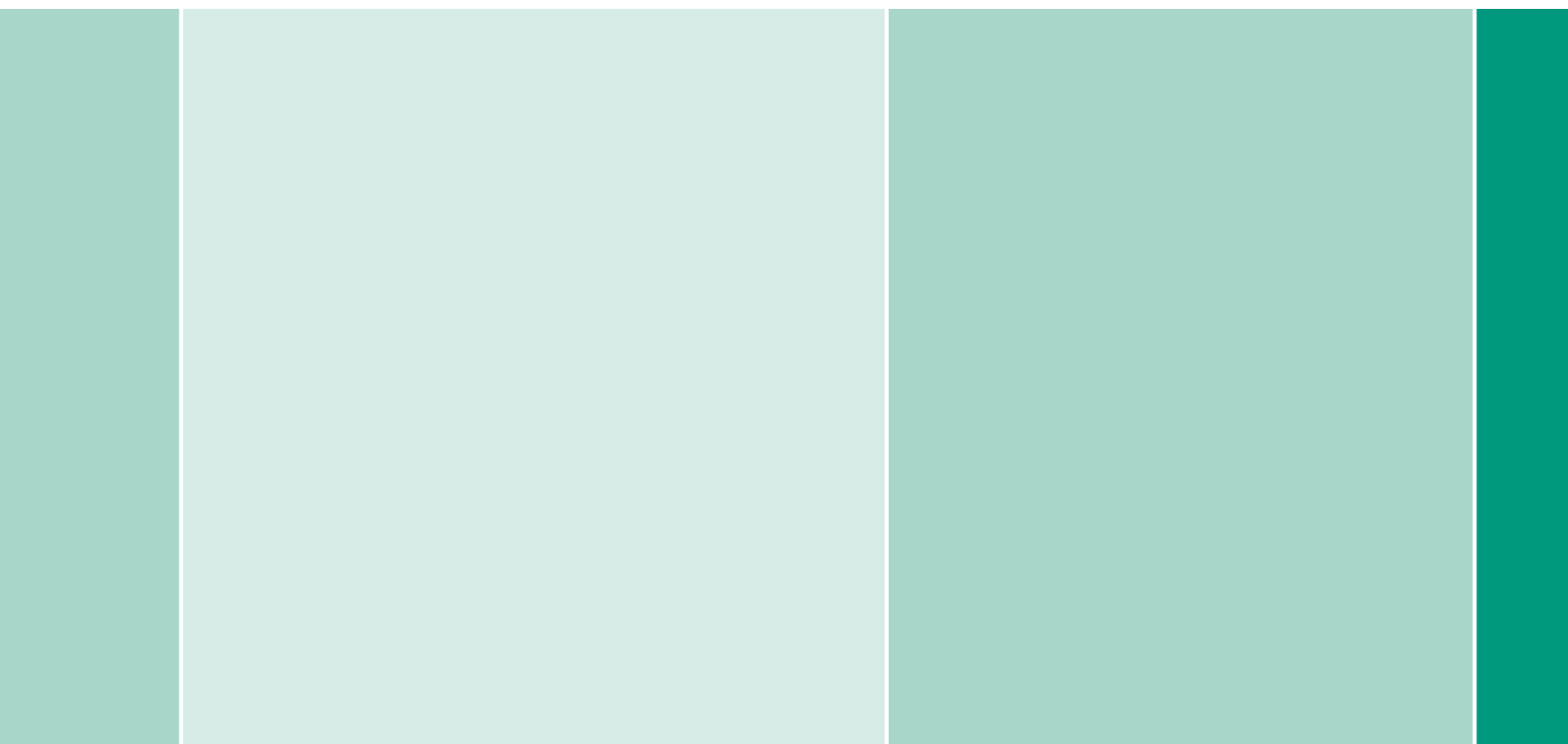

Aesculap AG | Am Aesculap-Platz | 78532 Tuttlingen | Germany  
Phone +49 7461 95-0 | Fax +49 7461 95-26 00 | [www.aesculap.com](http://www.aesculap.com)

Aesculap – a B. Braun company

The main product trademark 'Aesculap' and the product trademarks 'MINOP TREND' and 'Unitrac' are registered trademarks of Aesculap AG.

Subject to technical changes. All rights reserved. This brochure may only be used for the exclusive purpose of obtaining information about our products. Reproduction in any form partial or otherwise is not permitted.

Brochure No. C87511

0812/0.5/1